

GENERAL

The IL Gas Vent System is manufactured with an aluminium liner and a galvanised steel outer case, separated by a 6mm air gap annulus. Each system is to be used as manufactured and apart from the Draughthood Connector and Adjustable Length, MUST not be cut, drilled or altered in any way.

1 MANDATORY REQUIREMENTS

Connection to an appliance which is not connected to the fuel supply can be carried out by a competent person. However connection to an appliance which IS connected to the fuel supply MUST be carried out by a registered installer e.g. Gas Safe. Installation of the flue system must comply with Building Regulations Document J in England, Wales and Northern Ireland for gas appliances having a maximum flue gas temperature of 250°C and the Building Regulation for Scotland. The installation must also comply with BS 5440 Part 1 for gas appliances up to 60kW in the UK and IS813 Domestic Fuel Installations in Ireland.

2 CLEARANCE FROM COMBUSTIBLES & LOCATION

Building Regulations require that the external surface of any flue venting products of combustion from a gas fired appliance, (or oil fired where the flue gas temperature is below 250°C), MUST be kept clear of any combustible material. All SFL support and penetration components within the IL system provide 50mm air gap clearance.

IL can be applied internally or externally, however, care should be taken to avoid excessive cooling of the combustion products. IL Gas Vent MUST not be used externally if the run exceeds 3 metres. Where the run exceeds 3 metres, then an insulated product such as the SFL Nova or Sflue should be used.

3 FIXED FLUE SYSTEMS

Where IL is to be used to connect to a BS EN 1806 Gas Flue Block system, connection into the Transfer/ Adaptor block must be made with a Draughthood Connector and the joint thoroughly sealed with fire cement or a high temperature silicone sealant. However, it is known that a badly constructed Gas Flue Block system can result in a significant drop in flue gas temperature, such that condensation may occur. Therefore it should be ensured that there are no leaks or mortar projecting into the block flue way. If the system is likely to be located in a cold area, i.e. ventilated roof areas, then it would be advised to use an insulated chimney system such as SFL Nova.

Note that BS 5440 Part 1, prohibits the connection of some types of gas fired appliance to Gas Flue Block systems, unless they have been specifically assessed for such application. If in any doubt, consult the appliance manufacturer, regulatory body or BS 5440.

4 APPLICATION

IL is designed for natural draught and dry operation where the flue gas temperatures will not exceed 250°C. Under no circumstances should IL be used where the appliance is capable of producing high levels of condensation or positive pressure within the chimney system. For applications that require positive pressure capability and condensate resistance, either our Supra Plus or Nova products should be considered.

A straight and vertical flue provides the most effective evacuation of the products of combustion. Whilst the range of components provide considerable route options, excessive changes in direction and lengthy angled runs create considerable resistance to the movement of the flue gases. No part of the flue system shall be at an angle of more than 45° degrees from the vertical. This is a Building Regulation and British Standards requirement. Whatever the configuration, always ensure that the first section of flue rises not less than 600mm vertically from the appliance connection / Gas Flue Box before a change in direction. As a general rule, the vertical distance between the appliance and the flue terminal should always be twice the horizontal distance between the appliance and the terminal. See Fig. 1.

5 CLEARANCE FROM COMBUSTIBLES

A minimum of 50mm clearance MUST be provided between the outer case of the product and any combustible material. All support and penetration components are capable of providing up to 50mm clearance from the outer case.



INSTALLATION INSTRUCTIONS IL FLUE SYSTEM



IL Product Designations To BS EN 1856-1

IL	EN1856-1	T250	N1	D	Vm	L11030	O50
----	----------	------	----	---	----	--------	-----

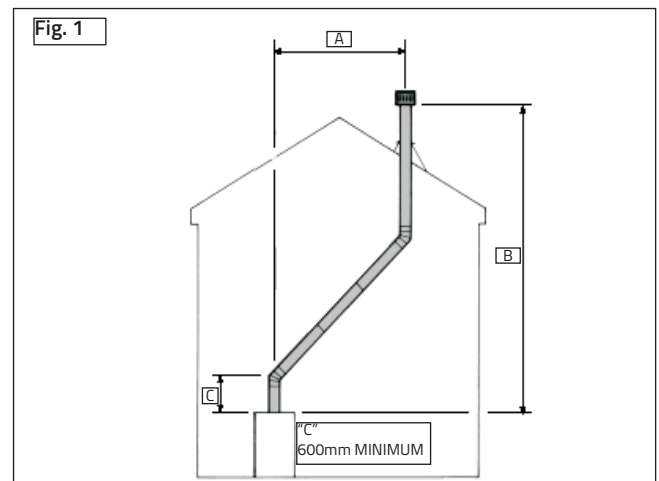

6 JOINTING COMPONENTS

All pipe lengths and fittings must be installed with the male coupler upwards and the female coupler downwards, fitting over the male, as shown below. Ensure that the ends are round and undamaged, if this is not the case, hand manipulation may be necessary to correct the roundness of the component prior to assembly of the joint. To assemble, line up the 3 dimples on the male and female couplers as shown, push the components together and turn to lock firmly. See Fig. 2

Fig. 2

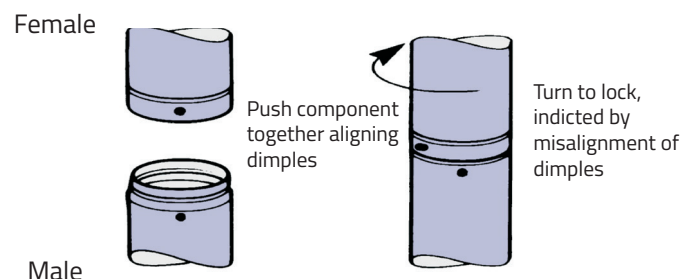

NB For clarity, dimples shown larger than actual size.

COMPONENT APPLICATION

7 CONNECTING TO THE APPLIANCE - Appliance

A Draughthood Connector/Appliance Connector **MUST** always be used to connect the system to the appliance. The inner liner must be fitted inside, but **NOT** projecting below the spigot/outlet of the appliance, and can be cut to an appropriate length.

8 CONNECTING TO THE APPLIANCE - Gas Flue Boxes

Freestanding, Recessed and LFE 125 Gas Flue Boxes accept a straight connection **WITHOUT A DRAUGHTHOOD CONNECTOR**. The Back Boiler Box requires a Draughthood Connector to be attached to a straight length and passes through the hole in the top of the Box and into the boiler flue spigot. Both joints must be sealed with fibre rope and fire cement. **HANDLING:** The product is relatively easy to handle, but care should be taken when holding, fitting or assembling any part of the system.

Users are advised to take suitable precautions, gloves etc., to avoid injury on any sharp exposed edges.

9 DISCONNECTOR SECTION

This component may be used close to the appliance, preferably immediately above the Draughthood Connector. Un clipping the Lock Band will permit removal of the appliance without dismantling the flue system.

10 ADJUSTABLE LENGTHS

These provide flexibility in the height or length of a vent run and allow for adjustment between two fixed points. Position the Adjustable Length above the male end of a straight length and adjust to the required dimension. Position the separate band towards the end of the component and tighten the fixing.

11 TEES

These may be used at the base of the vent configuration (with a Tee Cap in the base or branch), so as to provide access for cleaning or inspection.

12 ELBOWS

Adjustable Elbows are for use with IL **ONLY** and can be used to form any angle from straight to 90°. Fig. 3 shows the positions to which the four segments must be set for specific angles. Other angles can be found by additional manipulation, and the Elbows can be used singly or in pairs to form offsets. See Fig. 4. Care should be exercised when adjusting the elbows to ensure that the proceeding segment is held tight while making adjustment to the adjacent segment. Trying to adjust the elbow from both ends may result in excessive force being exerted on the elbow segments and could lead to damage of the joint. Due to the nature of the adjustable design, some leakage may be experienced during flow testing. Whether this leakage is deemed significant under the guidance offered in the Building Regulations is a matter of expert judgement. If required, the elbow segments can be sealed with a foil duct tape for added assurance.

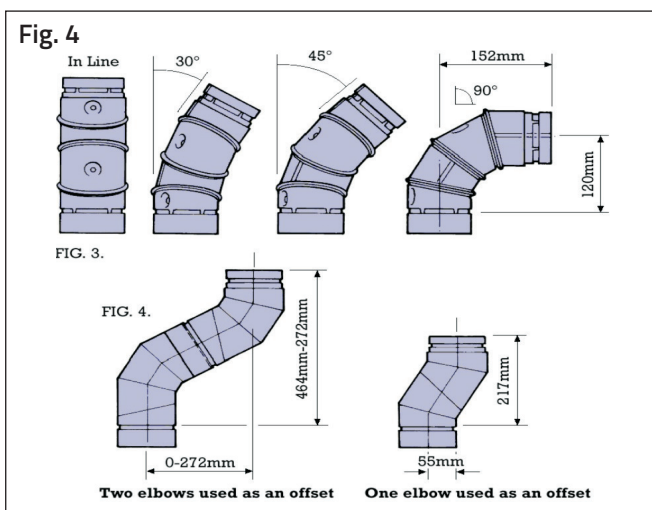

13 CEILING PENETRATION

Where the systems pass through a floor or ceiling without support, a Firestop Spacer must be used on both sides of the penetration to provide a barrier to fire and maintain a 50mm air gap clearance to combustible materials. If the systems are required to be supported where penetrating a floor or ceiling, Support Plates should be applied.

These must be fixed through the corner holes on the top of the floor joist or slab through which the system is passing. The flanged collar is clamped to the vent/flue so that the lower flange rests on the Support Plate.

A Firestop Spacer is to be used on the underside of the opening at ceiling level. The **MAXIMUM** height that can be supported, including any suspended lengths is 18m for IL. The combination of lengths and fittings should be such that no joints occur within the floor/ceiling space.

14 ADAPTION TO/FROM FLEXIBLE FLUE LINERS

There are two types of Adaptor used to connect IL with a BS EN 1856-2 approved stainless steel flexible flue liner. Fig. 5 illustrates the options and selection is vitally important as they fit only one way.

The easiest way to identify the correct Adaptor is by working up the system, from the appliance, i.e. IL Gas Vent from the appliance and connecting into a lined masonry chimney would be require an Adaptor to Flex version.

This connection would be made by attaching the Adaptor to the male end of the lower section of vent and locating the flexible liner inside the Adaptor top socket, secured with self tapping screws and sealed with fibre rope and fire cement to ensure a gas tight seal. Connecting from flexible liner requires a Flue Liner to IL Adaptor which is fitted by inserting this protruding liner on the underside into the flexible and secure with self tapping screws (not supplied). Seal the joint with fibre rope and fire cement. **DO NOT USE THE DRAUGHTHOOD CONNECTOR** for the latter option as IT IS NOT DESIGNED FOR AND WILL NOT FIT INSIDE A FLEXIBLE LINER.

15 WALL FIXING

In addition to structural support, the systems **MUST** be laterally supported using Wall Bands at intervals not exceeding 3m. Use fixings which ensure adequate attachment and support. Position the Band over the centre of any and all joints under tensile load and secure using M6 bolts supplied.

16 ROOF PENETRATION

The systems must be braced with a Wall Band secured to the roofing timbers where it passes through the roof line. If used with a Seldek Flashing to weather the system, follow the instructions supplied with the flashing. If using the aluminium flashing, position over the projecting section of the vent/flue, and weather to the tiles or slates as appropriate. Fix the Storm Collar over the Flashing and seal the joint with the silicone sealant provided. NB- If a lead flashing is used, make sure that the seal is thoroughly made so that the risk of galvanic corrosion cannot occur should the lead be in contact with the Zalutite outer case of the flue.

Fig. 5 Adaptor to / from Flexible

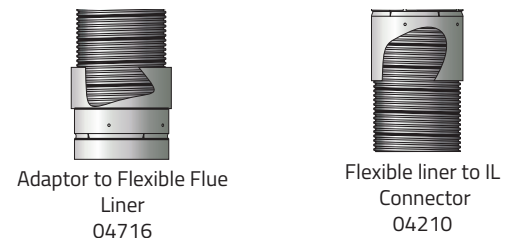

17 TERMINATIONS

There are several options in terminating the IL system:

Gas Vent Terminal- An aluminium terminal/cap, with a perforated sheet metal bird screen which allows rapid exhaust of combustion products.

NB In exposed coastal applications, consideration should be given for the use of an alternative type of terminal if conditions are likely to prevail where heavy driving consistent rain is possible.

Ridge Tile Adaptor - Used to adapt the system for venting to a rectangular opening on the underside of a Ridge Vent Tile which exhaust the products of combustion at the apex of the roof. Separate instructions are supplied with this component. See Fig. 6.

19 TERMINAL LOCATION

Terminals should be sited to allow the products of combustion to disperse freely and safely at all times. To avoid adverse wind or pressure effects which may impede vent flow, the termination must be correctly located in relation to the roof and any nearby structures. Building Regulations, via BS5440, stipulate minimum requirements shown in Figs 7 to 11.

A Ridge Tile Vent terminal must be positioned so that it is not less than 1.5m away from any adjacent structure, i.e. The gable end wall of an adjacent and higher dwelling. No part of the flue outlet shall be less than 1.5 m measured horizontally to the roof surface, or any wall. Where the flue terminates above the ridge, it shall do so by not less than 600 mm, other than where the flue terminates with a purpose designed ridge terminal, see Fig. 7.

Fig. 6 Terminal location for flues terminating at Ridge Vent Tile.

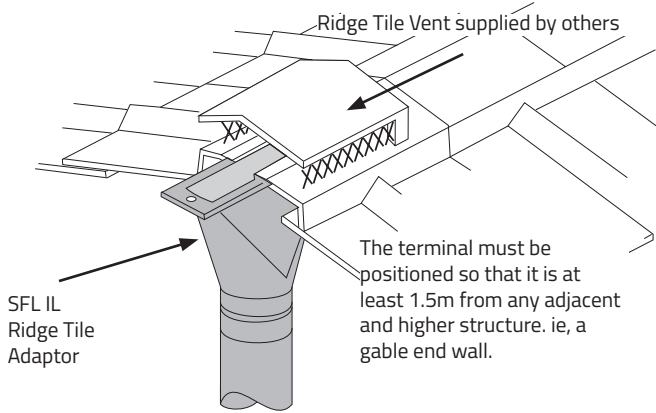

Fig. 7

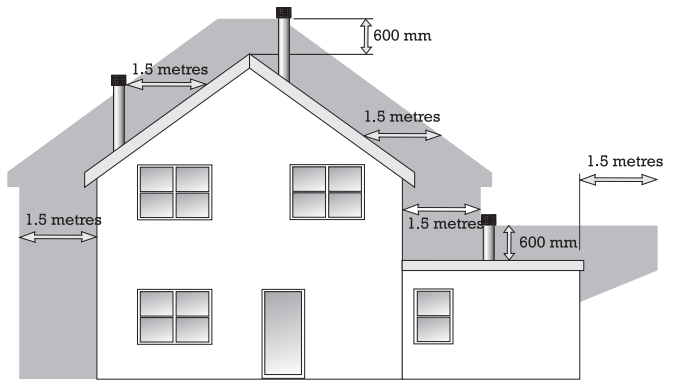
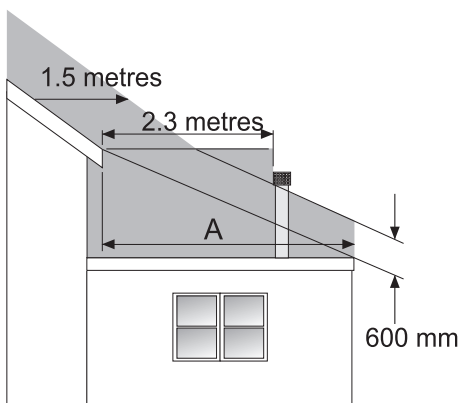
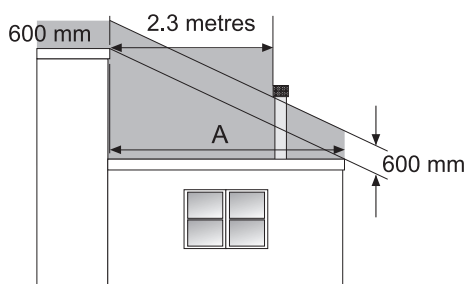

Fig. 8 Terminations above pitched roofs and extensions.



Extension adjacent a pitched roof building



Extension adjacent a flat roof building

The flue shall terminate outside of the shaded zone

Fig. 9 Termination above pitched roof with structures.

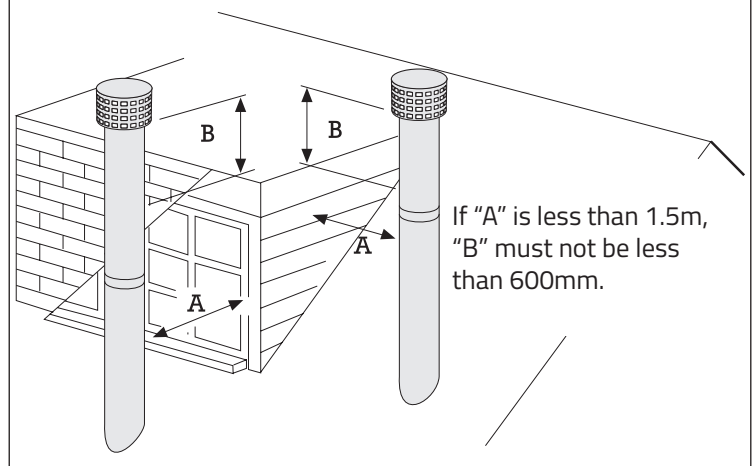
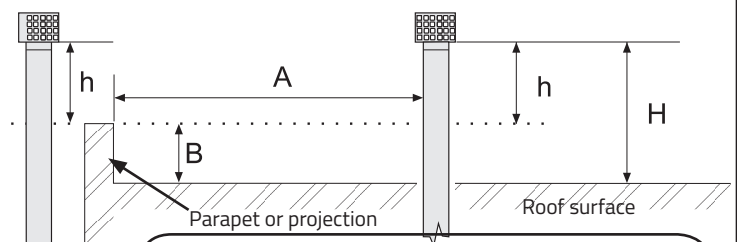

Fig. 10 Terminations above flat roofs with structures.



If the flue terminates through a completely flat roof with no projections or parapets, or if "A" is greater than 10 x B, "H" to be not less than 250mm.
 Where there are roof projections, then:-
 If "A" is 1500mm or less, "h" to be not less than 600mm.
 If "A" is greater than 1500mm, "H" to be not less than 600mm.
 If the roof has complex projections and structures, the termination is to comply with BS 5440:Part 1, Section 4

Where passing through or by a roof of an extension or lower part of a building, the terminal must be located not less than 2.3 metres from the structure. It must also terminate not less than 600mm above an imaginary line drawn between the outer edge of the extension, or 10 metres, (A), whichever the longer, and the edge of the higher roof, including any roof of an adjacent but separate building.

Fig. 11 Terminals on flues serving gas-fired appliances adjacent to windows or openings on pitched & flat roofs.

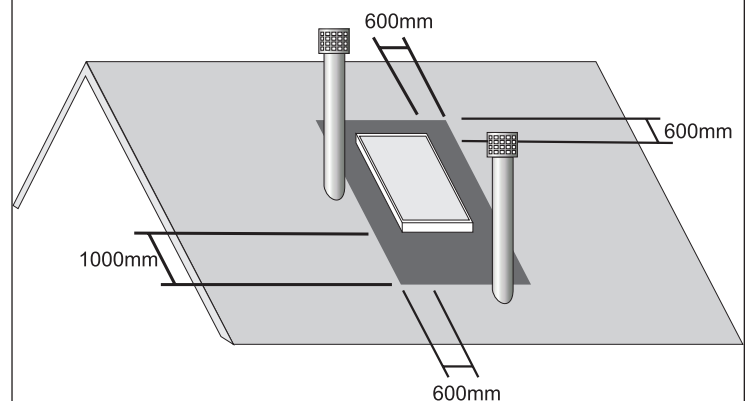

The chimney should not penetrate the dark shaded area

20 Maintenance

It is essential that the flue way is kept clear at all times. The system should be checked regularly at the same time as servicing / maintaining the appliance (refer to appliance manufacturers instructions).

21 Testing

This is achieved by means of a flue flow test as detailed in BS5440: Part 1. This can be summarised as follows:

After completing a visual and physical check of the system and joints, and ensuring adequate air supply for combustion has been provided in accordance with the appliance requirements, close all doors and windows in the room in which the appliance is installed.

Carry out a flow visualization check using a smoke pellet that generates at least 5m³ of smoke in 30s by placing the smoke pellet in the intended location of the appliance. Ensure that there is discharge of smoke from the correct terminal only and no leakage into the room. When the chimney is tested, there should be:

- No significant escape of smoke from the appliance position.
- No seepage of smoke over the length of the chimney.
- A discharge of smoke from only the correct terminal.

If these conditions are not met, then the test has failed and all faults must be rectified and the system re-tested and passed before connection of the appliance to the fuel supply is undertaken. For further information please refer to the relevant standards and publications.

Note: A smoke test is subjective and by the nature of the product standards a chimney is allowed a degree of leakage as defined in BS EN 1856. For this reason some wisps of smoke may be seen over the length of the chimney and this should not necessarily constitute a failure. For further information and guidance please refer to Appendix E of the Building Regulations Part J. Although taping of the joints with a suitable duct tap is not required, this exercise can be undertaken should the installer feel it is necessary in light of the above.

22 Data Plate

It is a regulatory requirement that a data plate is to be completed, positioned and secured by the installer where a hearth, fireplace, flue or chimney is provided or extended. The data plate provides essential information regarding the performance, specification, designation and installation for the chimney system. The data plate is to be completed by the installer using an indelible ink and securely fixed in an unobtrusive but obvious position. Acceptable fixing positions would be next to the electricity consumer unit, water supply stop cock or gas meter within the building or by the chimney / hearth. Data Plates for this purpose are available from SFL, please contact Customer Services for more information.

Some data plates contain more or less information than detailed below, it is a requirement that all data plates have to provide the essential information deemed necessary under the regulatory requirement, as follows:-

- Property address.
- Where the chimney / hearth is installed.
- What fuels the chimney is suitable for (firing capacity).
- Is the chimney suitable for condensing appliances / applications.
- Chimney internal diameter.
- Installers name and address.
- Date of installation.
- Distance to combustible material.
- Product designation of the chimney to EN 1443 / EN 1856-1, if relevant (See Product Information).

SFL

Pottington Business Park

Barnstaple

Devon. EX31 1LZ

Tel: +44 (0) 1271 32 66 33

Fax: +44 (0) 1271 33 43 03

Internet: www.sflchimneys.com

Email: info@sflchimneys.com

Typical Data Plate



IMPORTANT SAFETY INFORMATION 	
Property Address: The House, High Street, Bristol, Avon	
The chimney installed in the	Are suitable for (Fuel Type)
<input type="checkbox"/> Ground Floor <input type="checkbox"/> Lounge <input checked="" type="checkbox"/> Kitchen <input type="checkbox"/> First Floor <input type="checkbox"/> Dining Room <input type="checkbox"/> Boiler Room	<input checked="" type="checkbox"/> Gas <input type="checkbox"/> Oil (... Sicc) <input type="checkbox"/> Solid Fuel <input type="checkbox"/> All Suitable for condensing appliances <input checked="" type="checkbox"/> Yes <input type="checkbox"/> No
Chimney Designation to BS EN 1443	Condense Resistance <input type="checkbox"/> V1 <input checked="" type="checkbox"/> V2 <input type="checkbox"/> V3 <input type="checkbox"/> Vm
Temperature Pressure Capability <input checked="" type="checkbox"/> T200 <input checked="" type="checkbox"/> P1 (40Pa @ 0.01 s ⁻¹ m ³) <input type="checkbox"/> T450 <input type="checkbox"/> P1 (20Pa @ 0.008 s ⁻¹ m ³) <input type="checkbox"/> T600 <input type="checkbox"/> H1 (500Pa @ 0.008 s ⁻¹ m ³)	<input type="checkbox"/> W (WET) <input checked="" type="checkbox"/> D (DRY) Distance to combustible material (XXX) 50 mm 
Internal diameter of chimney 150 mm	Chimney Product Brand: iFlue
Installation Details	
Company Name: Wonder Plumb Services	Installed by: A Plumber
Address: _____	Date of Installation: 3rd September 2006
City: _____	
Country: _____	
Post Code: _____	
Phone Number: _____	
Important Information This chimney system must be cleaned and inspected on a regular basis. In any event, this should not be less than once per year and should be undertaken by an authorised sweep. Under no condition should black steel sweeping brushes or chemical chimney cleaners be used with this product. It is a requirement both under Building Regulations and CE that this plate is completed and installed within the guidelines contained therein.	

Fig. 13 Connection to a flexible liner in chimney

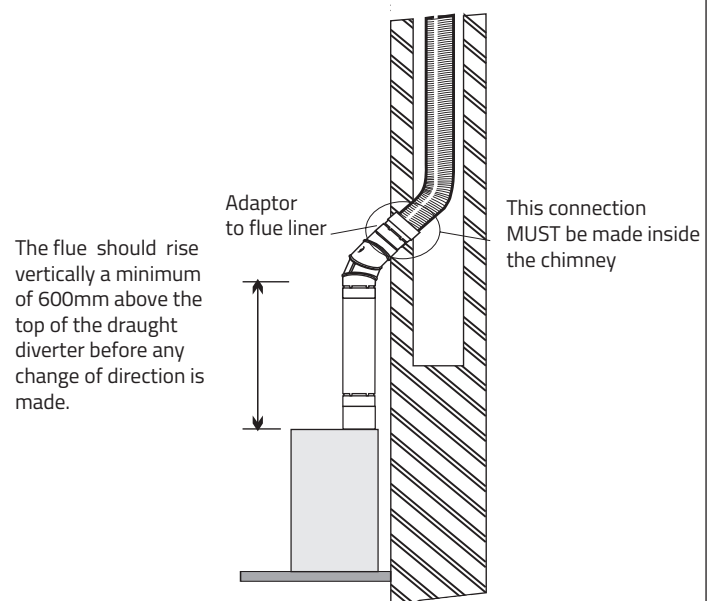

Fig. 14 IL Gas Vent used on a Gas Flue Block system

