

# ILS

Twin wall  
Insulated Cavity  
Stainless Steel & Zalutite  
Flue System for Kerosene  
and Gas Fired Appliances

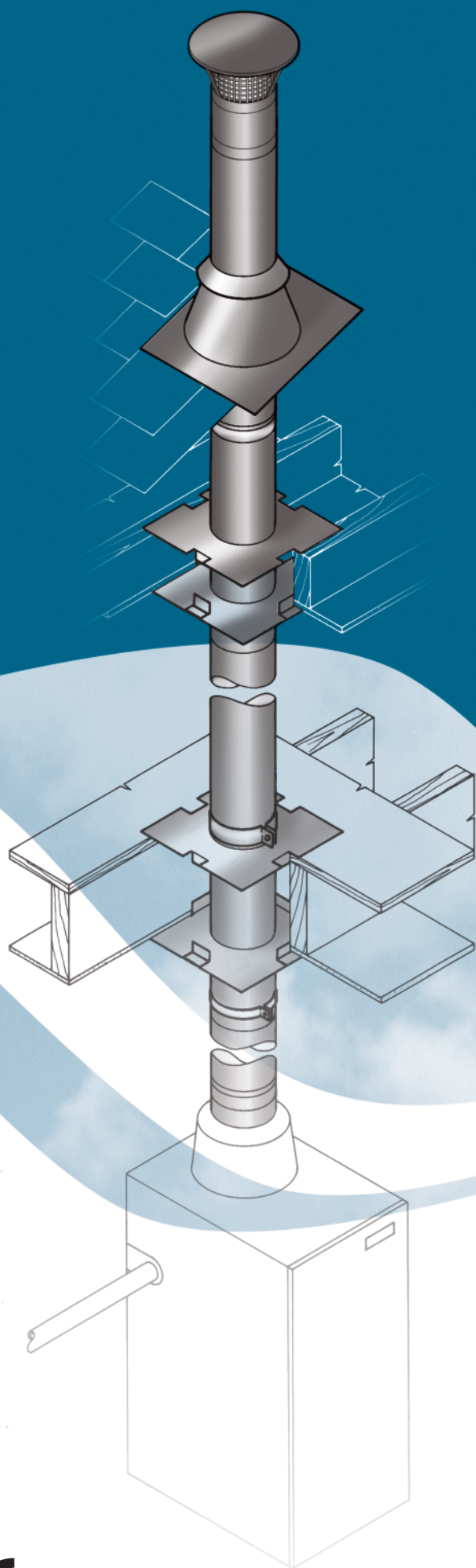

CE

  
**SFL**  
flues & chimneys  
Solutions For Life

INTRODUCTION

The ILS Flue System has been purposely designed for internal and external use with oil fired heating equipment, burning low sulphur content 28 sec. viscosity oil, viz., kerosene. ILS is based on the design of , and manufactured to the same high quality characteristics of the well established and proven IL Gas Vent System. As such, ILS is also suitable for use on draught-hooded gas fired equipment, where for technical reasons, the application may require a stainless steel lined product. ILS and IL are completely interchangeable and as such require no additional fittings to connect one with the other. The ILS Flue system may also be used where greater thermal efficiency within the flue is required, such as exposed external runs, flues located within vented roof spaces, and with high efficiency gas fires. Where used with gas fired appliances, the installation requirements are as defined in the separately available IL Gas Vent literature.

The insulation between the outer case and inner lining insulates the flue and thus ensures a strong draft at the start of firing to minimise condensation. The resulting low external temperature under operating conditions permits installation with only 50mm (2in) clearance to combustible materials.

Lengths and fittings lock together positively to provide a strong rigid flue system and to ensure maximum ease of site assembly. Available in three diameters from 100mm to 150mm (4in to 6in).

APPLICATION

The ILS Flue System is suitable for gas and kerosene appliances, typically in domestic or small commercial installations, with draught-hoods and where there is zero or negative pressure at the flue outlet.

There are several types of appliances which are in this category and the following recommendations apply for SFL products:

- a. Condensing/Vapourising Burner - Flue Gas Temperature at or below 160°C - Condensation is likely to be excessive - Use Supra with seals/Nova SM with seals.
- b. Non Condensing Appliance - Flue Gas Temperature 160°C to 250°C - ILS is suitable for these applications.
- c. Non Condensing Appliance - Flue Gas Temperature over 250°C - SM250/SMW/Nova SM is suitable for these applications.

**Note: Gas Appliances**  
**ILS is unsuitable for use with Decorative gas fires, unless they are manufactured to comply with BS 7977-1, or have specific flue diameter/type references in their respective approval documentation. If the gas appliance is of the vertex type, ILS is unsuitable as BS5440 Part 1 requires such systems to be served by a stainless steel sealed system such as Supra.**

Authority

The ILS Flue System must be installed to comply with the requirements of BS 5440 Part 1. Code of practice for flues and air supply for gas appliances of rated input not exceeding 70kW, the requirements of Approved Document J of the D.O.E. Building Regulations and Section F of The Building Standards (Scotland) Regulations.

Quality/Approvals

The ILS product is manufactured and certified to BS EN 1856-1 and tested to BS EN 1859 to the performance designations as defined in Table A. Products unless otherwise stated are CE certified under our FPC Certificate 0086-CDP-496040.



All components are manufactured under a Quality Assurance Scheme, certificate No. FM557622, administered by British Standards in accordance with BS EN 9001:2008. In addition, SFL operates a CE approved Factory Production Control System as required under the Constructions Products Directive 93/68/EEC.

Table A - ILS Product Designations To BS EN 1856-1

Cert. No: 0086-CPD-496040   ILS   BS EN 1856-1   T250   N1   D   Vm   L50050   0(50)	
Product	_____
Standard Number	_____
Temperature Class	_____
Pressure Class	_____
Condense Resistance D=Dry W=Wet	_____
Corrosion Class	_____
Material Specification Liner: 316L Liner Thickness: 0.5mm	_____
Sootfire Resistance G=Yes O=No	_____

DESCRIPTION

Composition and manufacture

All lengths and fittings are fabricated with a Zalutite outer case and a stainless steel inner liner. The inner and outer casing are joined at one end only and a 6mm (1/4in) insulated cavity is incorporated: the inner liner is thus free to expand as the temperature changes in the flue. The various components are jointed on-site by a simple swaged locking joint.

Size range

The system comprises three diameters to provide for appliances rated up to 75kW (63,000kcal/h, 250,000Btu/h). Unless otherwise stated, all fittings and accessories are available in the three sizes.

INSTALLATION

Installation Instructions will be found on pages 6 & 7 and are provided with several components and are also available on request.

Jointing

All lengths and fittings are designed to be installed with the male coupling uppermost. The female swaged coupling of the next component is simply pushed into place and twisted to provide a firm and secure connection by a simple locking device. See fig 2 on page 6.

Supports and clearance from combustibles

Wall bands are available in the full range of sizes to suit the ILS Flue System and, for wall-fixed installations should be used at 3m (10ft) centres. The bands give a nominal 50mm (2in) clearance to the wall and provide lateral stability.

**Note: Where the ILS Flue System extends more than 1 metre above last support, (excluding the terminal), it MUST be braced.**

A Support Plate is available which, together with the Flanged Collar, provides support for the flue at floor penetrations. The thicker Support Plate is fixed on top of the floor joists or slab and the Flanged Collar is clamped around the flue. The flange rests on the plate. A Firestop Plate is used on the underside of the ceiling penetration. Both components provide a 50mm (2in) minimum required air gap clearance from combustibles.

The maximum height of flue that can be supported is 10m (32ft).

Lengths of Flue System

Four lengths are available from 152mm to 914mm (6in to 3ft) and these may be used in combination to make-up the required height. The installed length of each unit is 38mm (1 1/2in) less than the overall length.

INSTALLATION

In addition, an adjustable length is available to provide sufficient flexibility to obtain an exact length or height of flue. This unit telescopes over any standard length to permit extension from 75mm to 203mm (3in to 8in).

Roof penetrations

The Seldek Flashings are also ideal for the ILS Flue System. See separate literature. Alternatively, a range of aluminium flashings and storm collar can be used from the IL Gas Vent System.

**Note: If a lead flashing is used, make sure that the seal is thoroughly made so that the risk of moisture influenced corrosion cannot occur where the lead touches the outer skin.**

Terminations

Terminating components include a Raincap and Ridge Tile Adaptor manufactured in stainless steel for use with kerosene appliances. Where the system is used on gas appliances, an aluminium Ridge Tile Adaptor, and a fabricated aluminium Gas Vent terminal are separately available in the IL range. (Refer to separate literature). All types of terminals have been designed for effective exclusion of rainwater whilst permitting rapid exit of flue gases.

PRINCIPAL DIMENSIONS

Size (internal diameter)	Maximum outside diameter
100mm (4in)	114mm (4 1/2in)
125mm (5in)	140mm (5 1/2in)
150mm (6in)	165mm (6 1/2in)

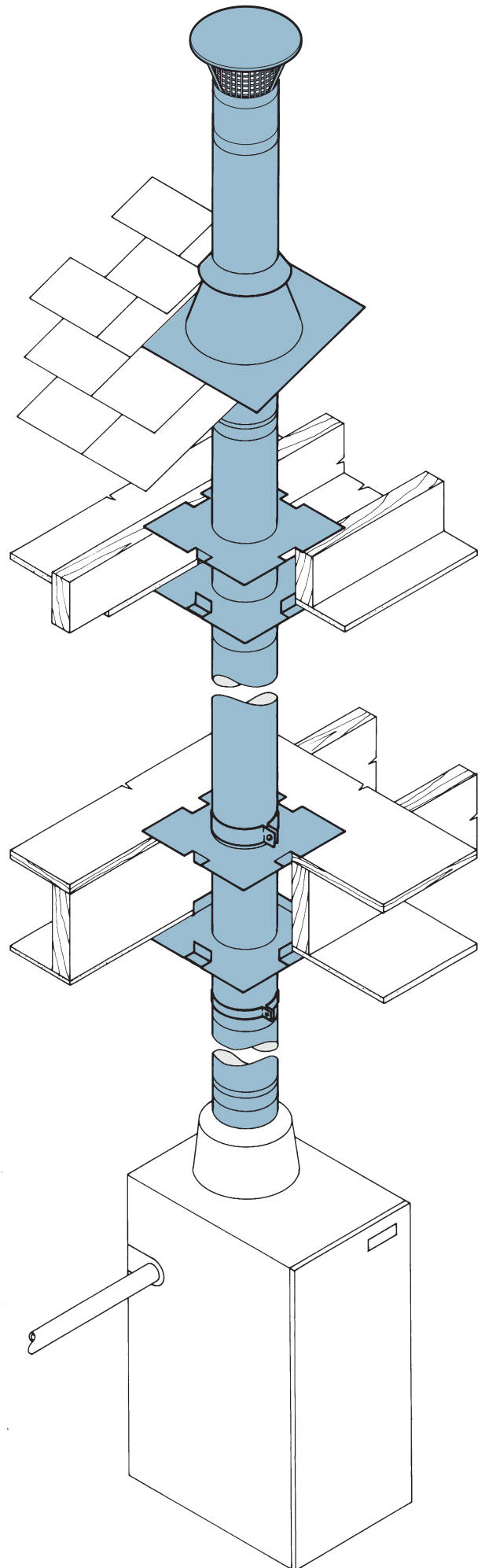
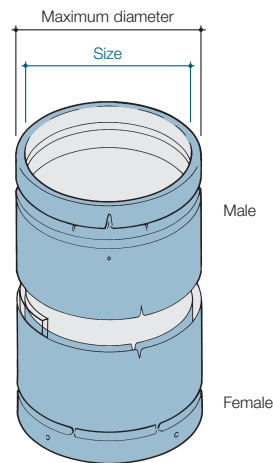

**LENGTHS**



**Straight Lengths**

Fixed straight lengths are available in four sizes: 152mm, 305mm, 457mm, and 914mm (*6in, 12in, 18in, and 36in*). Installed effective length is 38mm (*1 1/2in*) less than stated actual length.

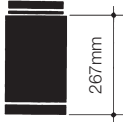

152mm (*6in*) lengths

Size	Code number
100mm <i>4in</i>	0901304
125mm <i>5in</i>	0901305
150mm <i>6in</i>	0901306



305mm (*12in*) lengths

Size	Code number
100mm <i>4in</i>	0901204
125mm <i>5in</i>	0901205
150mm <i>6in</i>	0901206



457mm (*18in*) lengths

Size	Code number
100mm <i>4in</i>	0901104
125mm <i>5in</i>	0901105
150mm <i>6in</i>	0901106

914mm (*36in*) lengths

Size	Code number
100mm <i>4in</i>	0900304
125mm <i>5in</i>	0900305
150mm <i>6in</i>	0900306

**Adjustable Length**

Available to ensure that an exact required flue height or length can be obtained.



305mm (*12in*) adjustable length

Size	Code number
100mm <i>4in</i>	0901504
125mm <i>5in</i>	0901505
150mm <i>6in</i>	0901506

**FITTINGS**

**Appliance Connector**

This component *must* be used to connect the system to an appliance spigot. It cannot be used as a substitute for the Adaptor to Flue Liner.

Size	A	Code number
100mm <i>4in</i>	105	0909304
125mm <i>5in</i>	105	0909305
150mm <i>6in</i>	105	0909306



**Increaser Appliance Connector**

This component is used to connect a 125mm system to an appliance which has a 100mm spigot and the flue size has to be enlarged, as recommended by the appliance manufacturer.

Size	A	Code number
125mm <i>5in</i>	105	0909405

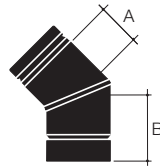

**45° Fixed Elbow**

Size	Dimensions		Code number
	A	B	
100mm <i>4in</i>	82	120	0902404
125mm <i>5in</i>	82	120	0902405
150mm <i>6in</i>	82	120	0902406

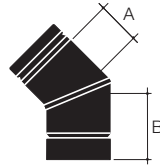

**30° Fixed Elbow**

Size	Dimensions		Code number
	A	B	
100mm <i>4in</i>	82	120	0902504
125mm <i>5in</i>	82	120	0902505
150mm <i>6in</i>	82	120	0902506

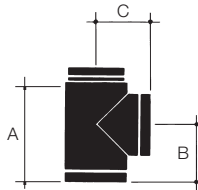

**90° Equal Tee**

Size	Dimensions			Code number
	A	B	C	
100mm <i>4in</i>	210	121	140	0904304
125mm <i>5in</i>	241	133	140	0904305
150mm <i>6in</i>	267	140	146	0904306

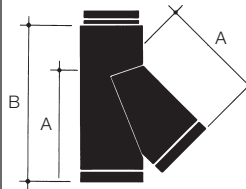

**135° Tee**

Size	Dimensions		Code number
	A	B	
100mm <i>4in</i>	285	419	0904404
125mm <i>5in</i>	285	419	0904405
150mm <i>6in</i>	315	419	0904406



**Condensate Collector**

Size	Code number
100mm <i>4in</i>	0903204
125mm <i>5in</i>	0903205
150mm <i>6in</i>	0903206

**Tee Cap**

Size	Code number
100mm <i>4in</i>	0905304
125mm <i>5in</i>	0905305
150mm <i>6in</i>	0905306

**ILS to Flex Adaptor**

Lower end of this all stainless steel component connects to standard product, upper end fits over flexible flue liner. Also used to connect to fibre cement flue liners.

Size	A	Code number
100mm <i>4in</i>	112	0902004
125mm <i>5in</i>	137	0902005
150mm <i>6in</i>	162	0902006

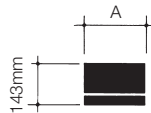

**Flex to ILS Adaptor**

Designed to be secured into the top of a stainless steel flexible flue liner at the point where the liner exits an existing masonry, or similar chimney. Connection would normally be in the roof space, and the ILS Flue System continues to termination in the normal manner.

Size	Dimensions		Code number
	A	B	
100mm <i>4in</i>	98	105	0901004
125mm <i>5in</i>	123	105	0901005
150mm <i>6in</i>	148	105	0901006

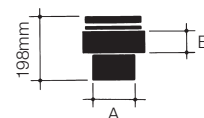

## FIXINGS & SUPPORTS

### Support Plate

Used to support the flue at floor penetrations in conjunction with the Support Flange (supplied).

Size	Dimensions		Code number
	A*	B**	
100mm 4in	224	254	0403204
125mm 5in	249	304	0403205
150mm 6in	270	304	0403206

\*framing spacing  
\*\*overall size of square plate

### Firestop Spacer

Used at floor or ceiling penetration or in conjunction with the Support Plate to maintain the required clearance to combustible materials.

Size	Dimensions		Code number
	A*	B**	
100mm 4in	224	254	0408704
125mm 5in	249	304	0408705
150mm 6in	270	304	0408706

\*framing spacing  
\*\*overall size of square plate

### Wall Band

Use at intervals not exceeding 3m to provide lateral support. If used externally, the galvanised component will require suitable weather protection.

Size	Dimensions		Code number
	A	B	
100mm 4in	109	52	0908804
125mm 5in	126	56	0908805
150mm 6in	140	58	0908806

### Wall Support

Size	Dimensions			Code number
	Dia A	B	C	
100mm 4in	114	109	52	0903304
125mm 5in	140	126	56	0903305
150mm 6in	165	140	58	0903306

### Stand-Off Wall Bracket

Made from galvanised steel, this component is designed to provide internal lateral bracing support off a wall or structure. The strut can be cut to length to provide variation in wall clearance.

Size	Dimensions		Code number
	A max	A min	
100mm 4in	238	80	0429804
125mm 5in	240	80	0429805
150mm 6in	237	80	0429806

## TERMINALS

### Ridge Tile Adaptor

Designed to be used with any approved ridge tile vent.

Size	Dimensions		Code number
	A	B	
Stainless Steel:			
100mm 4in	288	49	0901804
125mm 5in	315	49	0901805

This item is also available in aluminium for use on Gas fired appliances, refer to separate IL brochure for details.

### RTA Extension Box

Code number 0901905

To be used in conjunction with the Stainless steel Ridge Tile Adaptor to provide clearance from roof trusses below Ridge Tile.

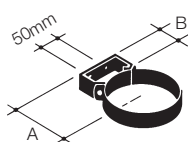
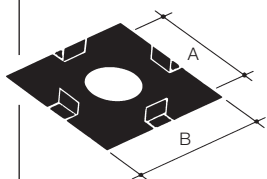
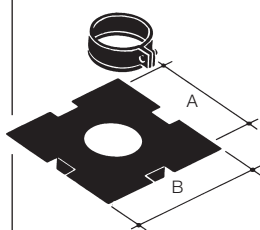

securing holes are 7mm diameter

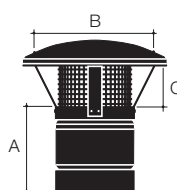
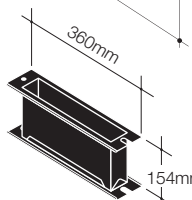
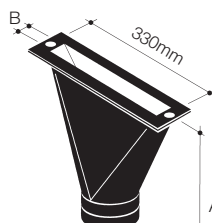
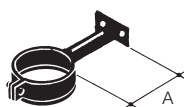
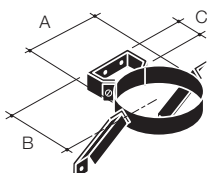

### Rain Cap

Size	Dimensions			Code number
	A	B	C	
100mm 4in	152	201	65.5	0907404
125mm 5in	152	201	72.5	0907405
150mm 6in	152	213	152	0907406

This item is supplied with mesh fitted to provide bird-guard properties

### Storm Collar

Used as weathering and supplied with sealant.

Size	Code number
100mm 4in	70123402
125mm 5in	70123403
150mm 6in	70123408



## COMPONENTS FOR GAS APPLICATIONS

Where the ILS Flue System is to be used specifically on gas and only on gas fired equipment, the following components can be ordered from the IL Gas vent range. These items are NOT suitable for use on kerosene appliances.

### Gas Vent Terminal

Fabricated aluminium.

Size	Dimension A dia	Code number
125mm 5in	211	07305
150mm 6in	238	07306

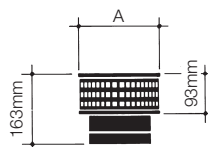

## SELDEK FLASHINGS

The Seldek flashing range will accommodate all SFL flue and chimney systems of external diameter between 60mm and 450mm. ILS is covered by 2 sizes of Seldek, depending on the angle or pitch of the roof. These provide a totally flexible solution for roof pitches from flat to 45°, and will effectively seal and remain pliant over a range of temperature extremes from -30° to 115°C.

ILS Roof Diameter	Seldek Pitch Angle	Code Flashing No.	Code Number
100mm	Flat to 45°	1	4901015
125mm	Flat to 40°	1	4901015
125mm	Flat to 45°	2	4901020
150mm	Flat to 40°	2	4901020

A range of aluminium flashings and storm collar are available as an alternative to the Seldek. Refer to IL brochure for details and order codes.

GENERAL

**THE ILS FLUE SYSTEM, WITH THE EXCEPTION OF THE APPLIANCE CONNECTOR AND THE ADJUSTABLE LENGTH, MUST NOT BE CUT, DRILLED OR ALTERED IN ANY WAY.**

**1 MANDATORY REQUIREMENTS**

*Building Regulations and BS 5440 Part 1* stipulate the minimum criteria for all types of chimney systems serving gas fired appliances. These instructions embody appropriate requirements.

**2 LOCATION**

ILS Flue System has an 316L stainless steel liner and a Zalutite outer skin, and can be applied both internally and externally. However, care should be taken to site the chimney so that it is not excessively cooled. Any galvanised components used externally should be suitably weather protected.

**3 FIXED FLUE SYSTEMS**

Where ILS is used to connect to a BS EN 1858 Gas Flue Block system, connection into the Transfer or Adaptor block must be made with a Appliance Connector, and the joint thoroughly sealed with a fire cement or high temperature silicone sealant. However, it is known that a badly constructed flue gas block system can result in a significant drop in flue gas temperature, such that condensation will occur. For that reason, where such "hybrid" systems are contemplated, it is advisable to ensure that the flue gas blocks have been correctly assembled, ie no leaks or projecting sealant/ mortar into the flue way. Note that BS 5440: Part 1, prohibits the connection of some types of gas-fired appliance to gas flue block systems, unless they have been specifically assessed for such application. If in doubt, consult the appliance manufacturer, CORGI, or BS 5440.

**4 APPLICATION**

A straight and vertical flue provides the most effective evacuation of the products of combustion. Whilst the ILS Flue System is extremely flexible, excessive changes of direction and angles greater than 45° from the vertical in any flue system must be avoided, as they will create considerable resistance to the movement of the flue gases. **HORIZONTAL RUNS SHOULD NOT BE USED** whatever the configuration. Always ensure that the first section of flue rises vertically from the appliance, a distance of not less than 600mm (2ft).

As a general rule, the vertical distance between the appliance and the flue terminal should always be twice the horizontal distance between the appliance and terminal. See Fig 1.

FIG. 1.

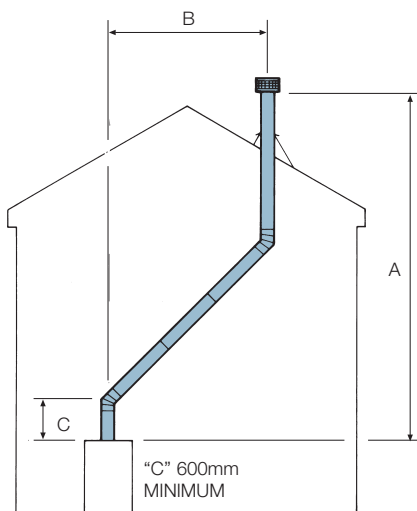

"A" should not be less than 2 x "B" or should be sized either in accordance with available Vent Tables, or the equivalent height data in BS 5440 Part 1.

**5 CLEARANCE FROM COMBUSTIBLES**

A minimum of 50mm (2in) clearance MUST be provided between the outer casing of the ILS Flue System and any combustible material. All the support components are capable of providing up to 50mm (2in) clearance.

**6 JOINTING COMPONENTS**

Flue pipe lengths and fittings must be installed with the male coupler upwards and female coupler downwards, fitting over the male. Make sure that the joining ends are round and undamaged. If the jointing ends appear out of round physically round the end by hand prior to making the joint. To assemble the components, line up the three dimples on the male and female couplers, push the lengths together and turn to lock firmly. See Fig 2.

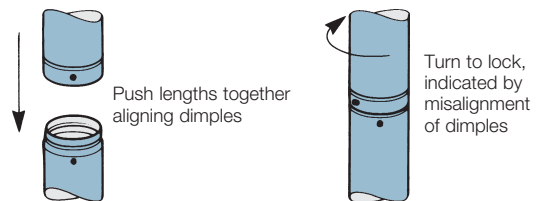

FIG. 2.

NB: For clarity the dimples are illustrated larger than actual size.

**7 CONNECTING TO THE APPLIANCE – Freestanding**

Always use a Appliance Connector to connect the ILS Flue System to the appliance spigot or draughthood. The inner lining must be fitted inside, but NOT project below the spigot/outlet and can be cut to an appropriate length.

COMPONENT APPLICATION

**9 ADJUSTABLE LENGTH**

This provides flexibility in the height or length of a flue run and allow for adjustment between two fixed points. Position the Adjustable Length over the top (male) of a straight length and adjust to the required dimension. Position the separate band towards end of the component and tighten the fixing.

**10 TEES**

These may be used at the base of the flue configuration, (with a Tee Cap in the base or branch), so as to provide access for inspection or cleaning.

**11 ELBOWS**

The following information provides details of dimensions where two similar angled elbows are used to provide an offset within the flue system.

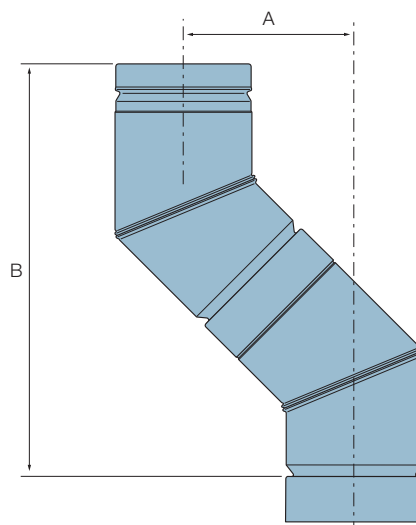

Angle	Dimension A	Dimension B
30°	101mm	377mm
45°	143mm	345mm

### 13 CEILING PENETRATION

Where the flue passes through a floor or ceiling without support, a Firestop Spacer must be used on both sides of the penetration to provide a barrier to fire and maintain a minimum 50mm (2in) air gap clearance to combustible materials. If the Flue system is required to be supported where it penetrates the floor/ceiling. Support Plates should be applied. These square heavy gauge galvanised plates must be fixed through the corner holes on top of the floor joist or slab through which the chimney is passing. The flanged collar is clamped to the vent so that the lower flange rests on the support plate. A Firestop Spacer must be used on the underside of the opening at ceiling level. The **MAXIMUM** height that can be supported, including any suspended lengths, is 10m (32ft). The combination of lengths and fittings used should be such that no joint occurs within the floor space.

### 14 FLEX TO/FROM ILS ADAPTORS

These fittings allow connection from ILS to a flexible flue liner or from a flexible flue liner to ILS. It is important to select the correct component, this is best achieved by working from the appliance upward, to determine the correct selection. These adaptors fit the appropriate end of the ILS flue system, the other is connected to the flexible flue liner, and is to be secured with self-tapping screws (not supplied). The joint should then be sealed with fire cement.

### 15 WALL FIXING

In addition to structural support, the ILS Flue System **MUST** be secured with wall bands at intervals not exceeding 3m (10ft). Use fixings which ensure adequate attachment and support.

### 16 ROOF PENETRATION

The system must be braced with a Wall Band where it passes through the roof line.

Seldek flashings are available for use with the ILS Flue System, see separate literature for full details. NB If a lead flashing is used, make sure that the seal is thoroughly made so that the risk of moisture influenced corrosion cannot occur where the lead touches the outer skin.

### 17 TERMINATIONS

Two methods of terminating ILS are available:

### 18 RAINCAP

A stainless steel terminal fitted with mesh to provide bird guard qualities and the rapid exhaust of combustion products.

### 19 RIDGE TILE ADAPTOR

A stainless steel fitting used to adapt the flue to the rectangular opening or Ridge Tile Vents which exhaust the combustion products only at the apex of the roof. Separate instructions are provided with this component. See Fig 5.

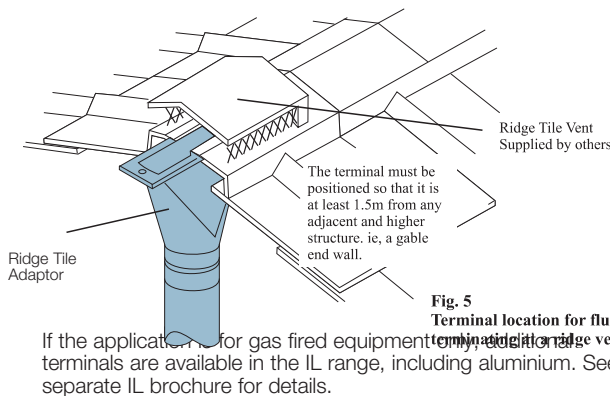

**Fig. 5**  
Terminal location for flues terminating in ridge vent.

If the application is for gas fired equipment terminals are available in the IL range, including aluminium. See separate IL brochure for details.

### 20 TERMINAL LOCATION

Terminals should be sited to allow the products of combustion to disperse freely at all times.

To avoid adverse wind or pressure effects which might impede vent flow, the termination must be correctly located in relation to the roof and any nearby structures. Building Regulations, via BS 5440, stipulate the legal requirements shown in Figs 5 to 8. NB A ridge tile vent terminal must be positioned so that it is not less than 1.5m from any adjacent structure. ie the gable end wall of an adjacent and higher dwelling. See Fig 5.

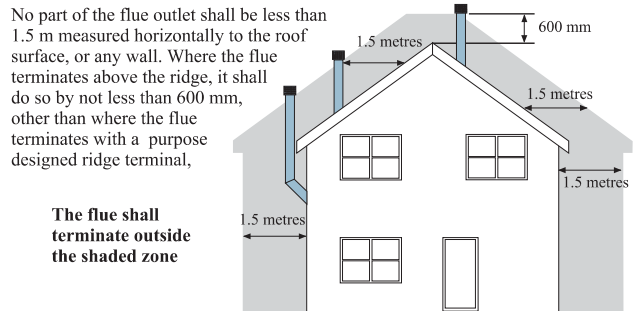

No part of the flue outlet shall be less than 1.5 m measured horizontally to the roof surface, or any wall. Where the flue terminates above the ridge, it shall do so by not less than 600 mm, other than where the flue terminates with a purpose designed ridge terminal,

The flue shall terminate outside the shaded zone

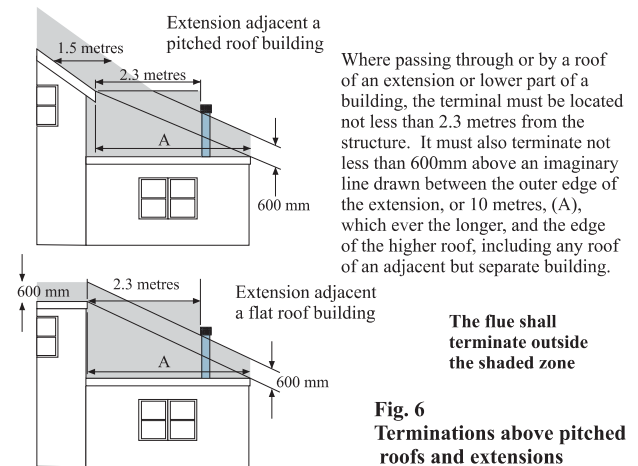

**Fig. 6**  
Terminations above pitched roofs and extensions

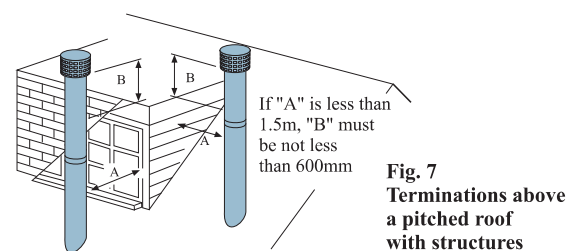

**Fig. 7**  
Terminations above a pitched roof with structures

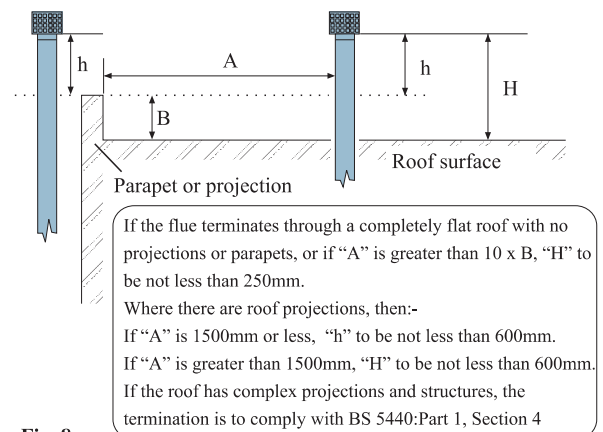

**Fig. 8**  
Terminations above a flat roof with structures

NB. Where the system extends more than 1 m, but no more than 1.5 m above the last support, (excluding the terminal), joints must be braced with a Joint Support Band. If it extends more than 1.5 metres, the extension above that level must also be braced with rigid stays.

The information contained in this brochure was accurate at the date of publishing. However the company reserves the right to introduce at any time modifications and changes of details as may be necessary. To avoid any misunderstanding, interested parties should contact the company to confirm whether any material alterations have been made since the date of this brochure.



**UK Sales and Customer & Export Services**

SF Ltd, Pottington Business Park, Barnstaple, Devon EX31 1LZ  
Tel: 01271 326633 Fax: 01271 334303 [www.sfchimneys.com](http://www.sfchimneys.com) [info@sfchimneys.com](mailto:info@sfchimneys.com)



In order to minimise the environmental impact on this publication, it has been printed locally, using vegetable based inks on FSC® certified paper.